



SCHLUMPF USA

ERGONOMIC HANDLING SOLUTIONS

Helping companies make thousands of every day products
faster,
safer,
and easier.



SCHLUMPF USA



Schlumpf USA was incorporated in 1992 as a wholly-owned subsidiary of Schlumpf AG of Switzerland, which itself dates back to 1886.

The company was sold to Chris van Haasteren, Schlumpf USA's CEO, at the end of 2009 following the death of Hans Peter Schlumpf, who long served as our leader and mentor.

Schlumpf USA is located in Windham (Portland), Maine. In January 2013 we moved our world headquarters to a beautiful new facility that doubled our office, engineering and production space to meet demand for our extensive line of products for the rolled goods manufacturing, converting and material handling marketplace. The new office space houses Schlumpf USA's sales, administration, production, engineering and service, as well as our sister companies: Sebago CNC & Armani USA.

39 Enterprise Drive
Windham, ME 04062

Tel: (207) 893-1903
Fax: (207) 893-1905
info@schlumpf-inc.com

CONTACTS

For information on our products, and what would best fit your application, contact our sales team!

SALES

Doug Jones - doug@schlumpf-inc.com - ext. 203

Dave Miklovich - dave@schlumpf-inc.com - ext. 214

Patrick Hoagland - patrick@schlumpf-inc.com - ext. 215



207.893.1903

PARTS & SERVICE

Michael Jones - michael@schlumpf-inc.com - ext. 211

For any of your spare parts and service needs, contact our Parts and Service department!

MEDIA & MARKETING

Meghan Vadeboncoeur - meghanv@schlumpf-inc.com - ext. 216

If you need any brochures, or have any video inquiries, contact our Media Department.



SCHLUMPF USA

Hoist Based Solutions

Hoist Based Material Handling Systems provide a wide range of placement and turning options.

- ◆ Flexible Packaging

- ◆ Food Packaging

- ◆ Pharma Packaging



- ◆ Medical Packaging

- ◆ Converting and Printing

- ◆ Aerospace

MRT-150

Manual Roll Turner

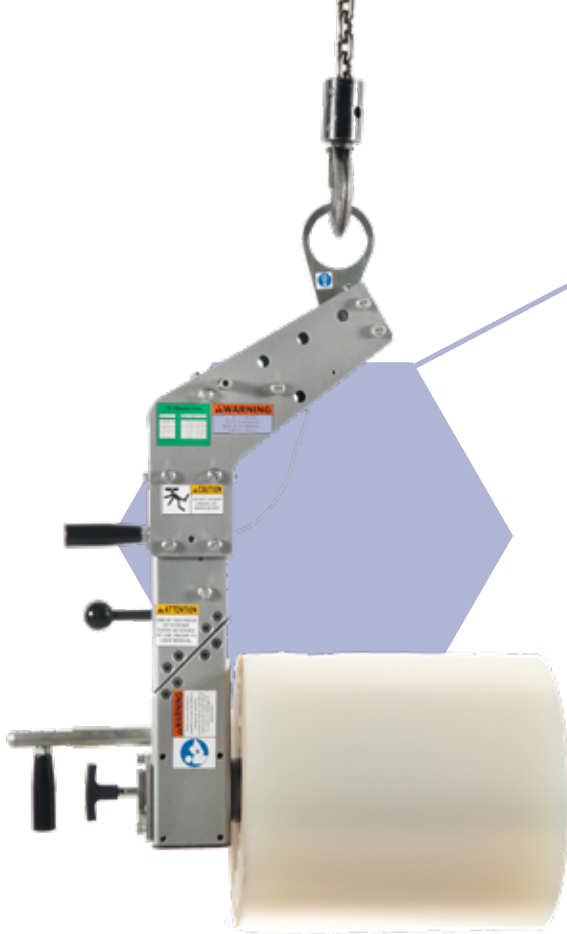

- ◆ Effortless, easy to use turning!
- ◆ Lift and Rotate rolls and reels between horizontal and vertical by the core
- ◆ Unload rolls and reels onto machine spindles or carts
- ◆ Loading or unloading pallets
- ◆ Universal Mandrel Holder for easy change between core sizes
- ◆ Capacities up to 150 lbs (68 kg)

Options

- ◆ Pneumatic Mandrel Retract
- ◆ Hoist Integration
- ◆ Anti-Telescoping Attachments
- ◆ Custom Mandrels
- ◆ Shaft Coupling
- ◆ Stainless Steel



**Anti-Telescoping Attachment*

Capacities dependent on roll specifications. Please contact us for more information.

MRT-330

Manual Roll Turner

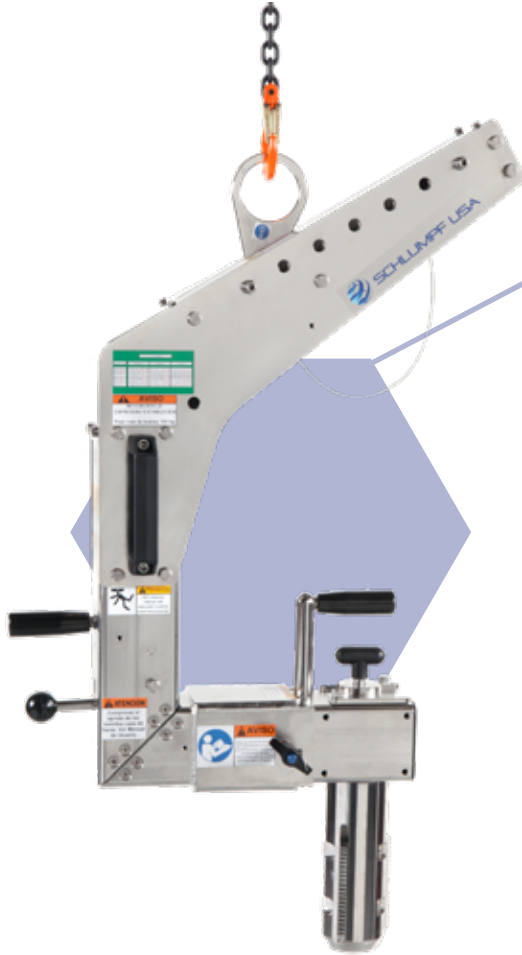

- ◆ Effortless, easy to use turning!
- ◆ Lift and Rotate rolls and reels between horizontal and vertical by the core
- ◆ Unload rolls and reels onto machine spindles.
- ◆ Transfer rolls and reels from a table to an HRC Portable Roll Cart
- ◆ Loading or unloading pallets
- ◆ Universal Mandrel Holder for easy change between core sizes.
- ◆ Adjustable turner arm for accommodating a wide range of roll widths
- ◆ Capacities up to 330lbs (150 kg)

Options

- ◆ Pneumatic Mandrel Retract
- ◆ Hoist Integration
- ◆ Anti-Telescoping Attachments
- ◆ Custom Mandrels
- ◆ Shaft Coupling
- ◆ Pneumatic Powered Turning
- ◆ Pneumatic Powered Pusher
- ◆ Stainless Steel



Capacities dependent on roll specifications. Please contact us for more information.

MRT-500

Manual Roll Turner



- ◆ Effortless, easy to use turning!
- ◆ Lift and Rotate rolls and reels between horizontal and vertical by the core
- ◆ Unload rolls and reels onto machine spindles or transfer on to carts.
- ◆ Loading or unloading pallets
- ◆ Universal Mandrel Holder for easy change between core sizes.
- ◆ Adjustable turner arm for accommodating a wide range of roll widths
- ◆ Capacities up to 500lbs (227 kg)

Options:

- ◆ Pneumatic Mandrel Retract
- ◆ Hoist Integration
- ◆ Anti-Telescoping Attachments
- ◆ Custom Mandrels
- ◆ Shaft Coupling
- ◆ Pneumatic Powered Turning
- ◆ Pneumatic Powered Pusher
- ◆ Stainless Steel



**Pneumatic options available*

Capacities dependent on roll specifications. Please contact us for more information.



SCHLUMPF USA

VRL-1000

Vertical Roll Lifter

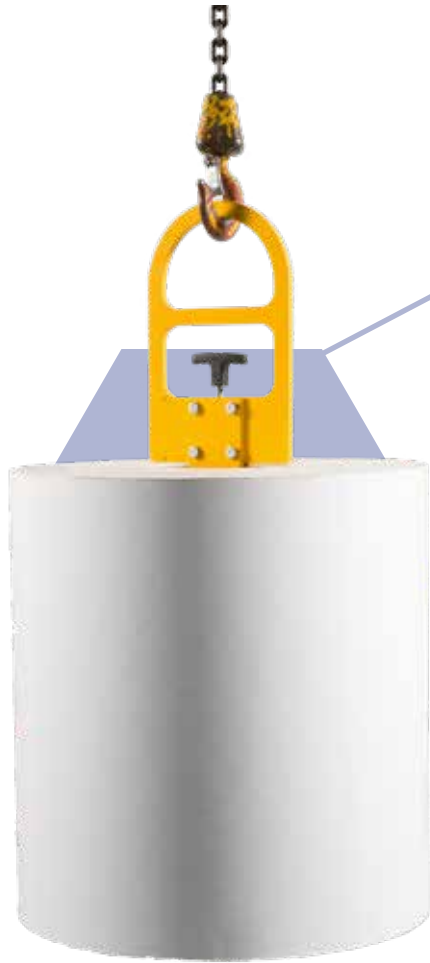

Schlumpf's vertical roll lifters, safely lift, load & stack rolls.

- Below-the-hook lifting devices attach to standard hoist hooks
- Safely lifts rolls by the core
- Fail safe gripper design securely holds rolls

The VRL-1000 can handle rolls up to 1000 lbs (454 kg), and is made for either 3in or 6in roll cores

This simple design effectively lifts any roll with a standard core size. It is easy to use and install!



Capacities dependent on roll specifications. Please contact us for more information.

VRL-2200

Vertical Roll Lifter



Schlumpf's vertical roll lifters, safely lift, load & stack rolls.

- Below-the-hook lifting devices attach to standard hoist hooks
- Safely lifts rolls by the core
- Fail safe gripper design securely holds rolls
- Changing between mandrel sizes is quick and easy.

The VRL-2200 can handle rolls up to 2200 lbs (1000 kg). It is great for handling large rolls that are vertical only, and can be used with a variety of core sizes

The VRL-2200 has our universal mandrel holder. It can hold mandrels of any size to accommodate the variety of cores you use!



Capacities dependent on roll specifications. Please contact us for more information.

VRL-1000/500-TA

Vertical Roll Lifter



Schlumpf's vertical roll lifters with tilt assist, safely lift, tilt and stack rolls.

- Below-the-hook lifting devices attach to standard hoist hooks
- Safely lifts rolls by the core
- Fail safe gripper design securely holds rolls
- No Pendulum effect!
- Universal Mandrel Holder

The VRL-1000-TA can handle rolls up to 1000 lbs (454 kg), there is also a lower capacity design that handles up to 500lbs (227 kg). Great for lifting and tilting rolls with its tilt assist feature.

The VRL-TA's unique pivoting hoist arm design gives the ability to tilt a roll onto its side in a controlled manner simply by using the hoists lifting function.

The tilt arm comes in several different lengths to accommodate a wide range of roll widths and diameters.

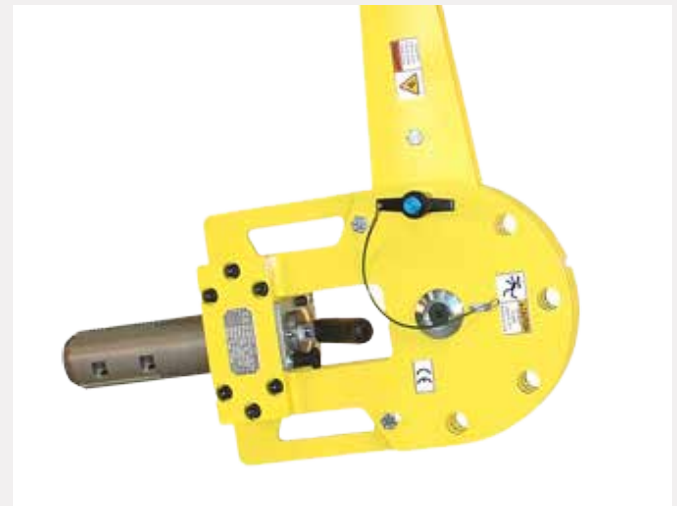

Capacities dependent on roll specifications. Please contact us for more information.

HRL

Horizontal Roll Lifter

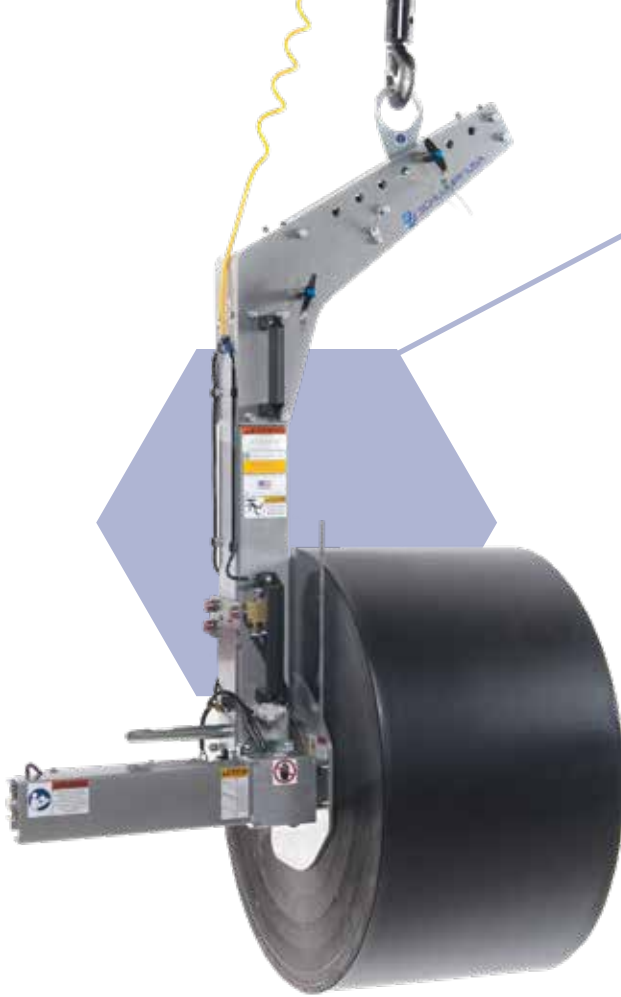

- ◆ Below-the-hook lifting devices attach to standard hoist hooks
- ◆ Lift roll by the core or by supporting the outside diameter
- ◆ Manual, powered and automatic load leveling systems available
- ◆ Multiple tooling options available, including cradle and probe.
- ◆ Pneumatic gripper retract and pusher systems available

The HRL has capacity options up to 1000lbs (454 kg).

Schlumpf's Horizontal Roll Lifters are used to transport rolls in a horizontal position.

The unit is supported by a hoist and allows operators to easily load or unload the rolls onto a machine spindle and to/from a roll cart or pallet.



Capacities dependent on roll specifications. Please contact us for more information.

VODC

Outside Diameter Clamp



- ◆ Lift and Rotate rolls/industrial parts between horizontal and vertical by the outside diameter.
- ◆ Unloading or loading rolls onto a machine spindle.
- ◆ Transfer rolls from a pallet to a machine.
- ◆ Custom Tooling options available.
- ◆ Clamp pressure adjustable to accommodate different materials

Our VODC series is custom tailored to fit your exact roll handling needs!

These units can lift not just rolls but also: billets, motor stators, valves, and other industrial parts!



Capacities dependent on roll specifications. Please contact us for more information.

CUSTOM

Hoist Based Solutions

Our engineers will custom design a solution to fit your specific hoist based needs!

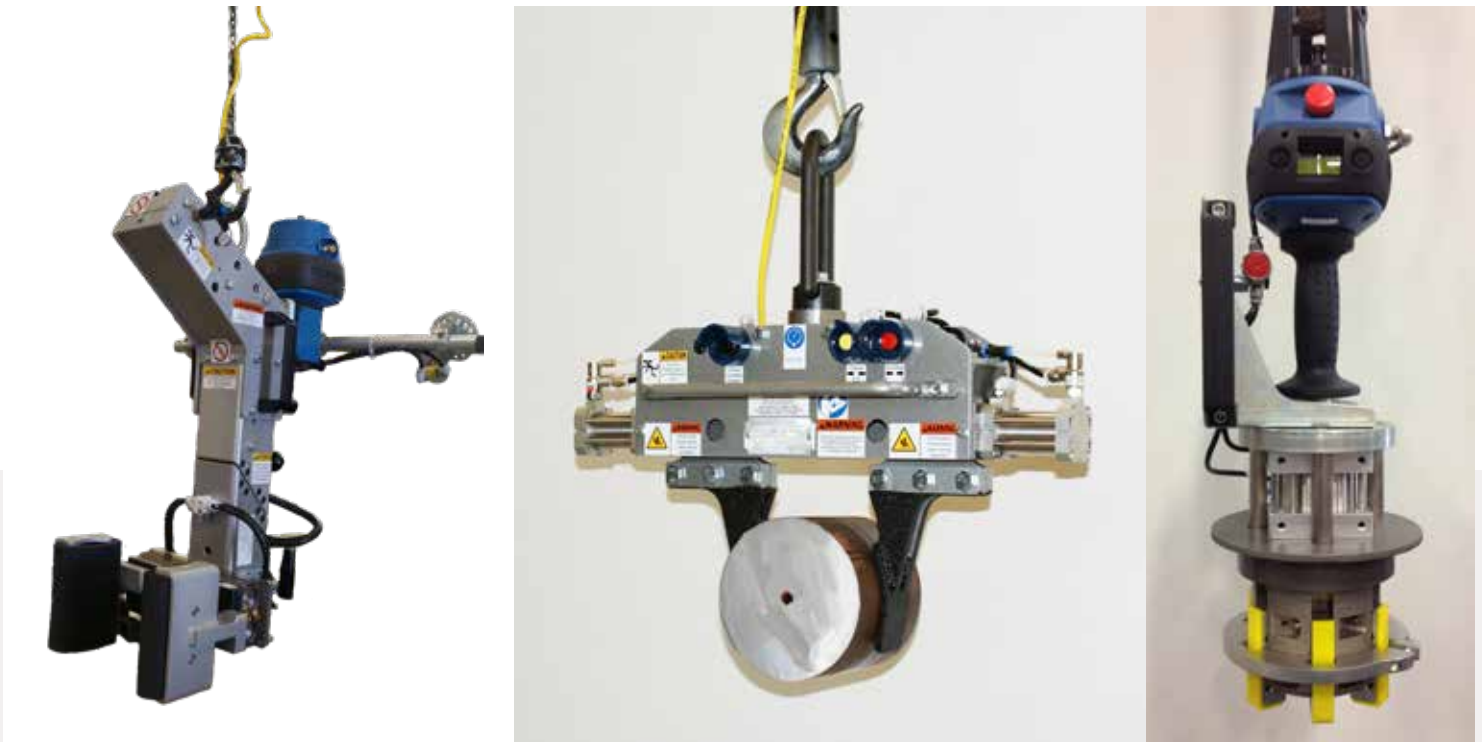

*Contact our sales team if you are interested
in a custom design!*



SCHLUMPF USA

Mobile Solutions

Schlumpf Material Handlers reduce the risk of both material damage and operator injury, saving your company money and valuable resources.

◆ Flexible Packaging

◆ Food Packaging

◆ Pharma Packaging



◆ Medical Packaging

◆ Converting and Printing

◆ Aerospace

ERH-200

Electric Roll Handler

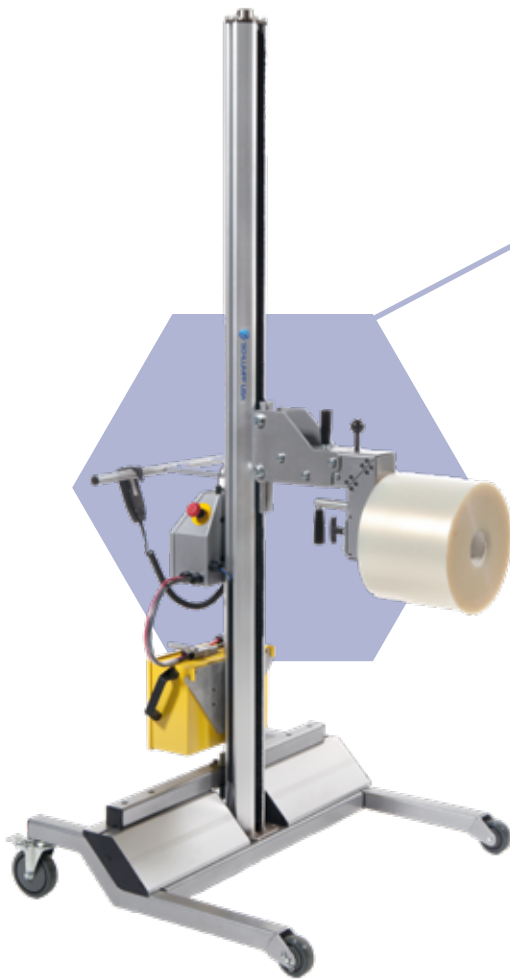

The ERH-200 is our lightest and most compact handling machine. Numerous tooling options are available for every application.

- ◆ Lightweight aluminum frame
- ◆ Customizable height
- ◆ Compact Euro or Adjustable Straddle base
- ◆ Powered Raise and Lower
- ◆ Several manual tooling options including: flat platform, roll cradle, probe, roll turner, and swivel top.
- ◆ Ergonomic and efficient!



Capacities up to
200 lbs (91 kg)!

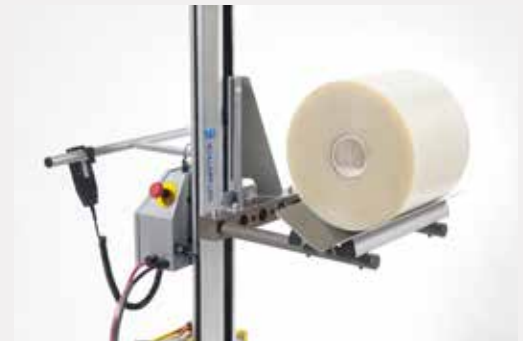

Capacities dependent on roll specifications. Please contact us for more information.



SCHLUMPF USA

ERH-400

Electric Roll Turner



The ERH-400 has capacities up to 400lbs, and is used to lift rolls for palletizing, transporting and loading.

- ◆ Lightweight extruded aluminum frame
- ◆ Easy to push and maneuver
- ◆ Tooling options: OD Clamp, ID/OD Clamp, Horizontal probe, roll turner, and more!
- ◆ Custom Tooling Options Available!

Options:

- ◆ Custom Column Heights
- ◆ Adjustable Straddle or Euro bases
- ◆ 4-Way Swivel Casters
- ◆ Pivot Tooling
- ◆ Camera System
- ◆ Roll Pusher... and more!



**OD clamp tooling*

Capacities dependent on roll specifications. Please contact us for more information.

MRH

Manual Roll Handler



With its maneuverable compact design, and multiple tooling options the MRH series is a safe, cost effective and adaptable solution for many lifting applications.

- ◆ Easy to use manual lift design.
- ◆ Plenty of tooling options including probes, turners, and cradles.
- ◆ Rugged and lightweight construction.

Capacities up to 500lbs (227 kg)!

Options:

- ◆ Custom Column Heights
- ◆ Straddle or Euro base
- ◆ Four-Way Swivel Casters
- ◆ Pivot Tooling
- ◆ Stainless Steel
- ◆ Low Profile



Capacities dependent on roll specifications. Please contact us for more information.

CUSTOM

Mobile Solutions

Our engineers can design a mobile machine to fit your exact specifications! Tailored designs ranging from OD clamping, to probes with pushers. We can accommodate any of your industrial material handling

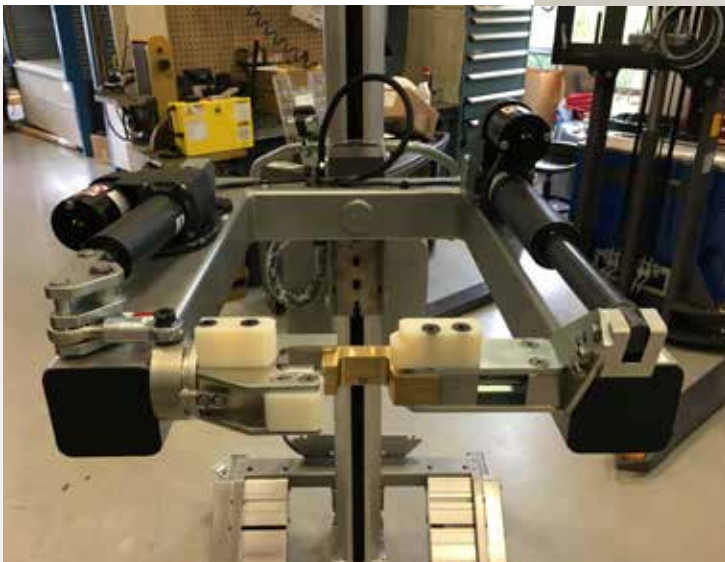

Contact our sales team if you are interested in a custom design!



SCHLUMPF USA

Powered Mobile Based Solutions

Schlumpf's heavy duty, portable, lift & turn handlers offer superior performance and quality.

Designed and manufactured by Schlumpf's world class team in Windham, Maine. Schlumpf is here to become your turnkey material handling and product supplier!

◆ Flexible Packaging

◆ Food Packaging

◆ Pharma Packaging



◆ Medical Packaging

◆ Converting and Printing

◆ Aerospace

PT10X

Powered Roll Turner



With its powerful Armani base truck, driving and maneuvering even in crowded work areas is safe and easy.

- ◆ Adjustable Straddle, Euro style, or Counter Balanced bases.
- ◆ Custom tooling options.
- ◆ Ergonomic Design.

Capacities up to 1500lbs (680kg)!

Options:

- ◆ Hydraulic Side shift
- ◆ Camera System
- ◆ Roll Pusher
- ◆ Dual Stage Mast
- ◆ Laser System



**Counter Balanced Machine*

Capacities dependent on roll specifications. Please contact us for more information.

PT20X

Powered Roll Turner



With its powerful Armani Delta base truck, driving and maneuvering even in crowded work areas is safe and easy.

- ◆ Adjustable Straddle, Euro style, or Counter Balanced bases.
- ◆ Custom tooling options.
- ◆ Ergonomic Design.

Capacities up to 2200lbs (1000kg)!

Options:

- ◆ Hydraulic Side shift
- ◆ Camera System
- ◆ Roll Pusher
- ◆ Dual Stage Mast
- ◆ Laser System



**Camera System*

Capacities dependent on roll specifications. Please contact us for more information.

OD CLAMPING

Powered Roll Turner



Turn rolls by clamping from the outside! These heavy duty clamps can handle even the heaviest of rolls with minimal effort!

- Ergonomic Design
- Custom Clamp Pads available for specific applications.
- 360° rotation

Capacities up to 3000lbs (1361kg)!

Options:

- Straddle or Counter Balanced legs
- Hydraulic Side shift
- Camera System
- Multiple Clamp Designs
- Dual Stage Mast



Capacities dependent on roll specifications. Please contact us for more information.

POWERED PROBE

Powered Roll Handler

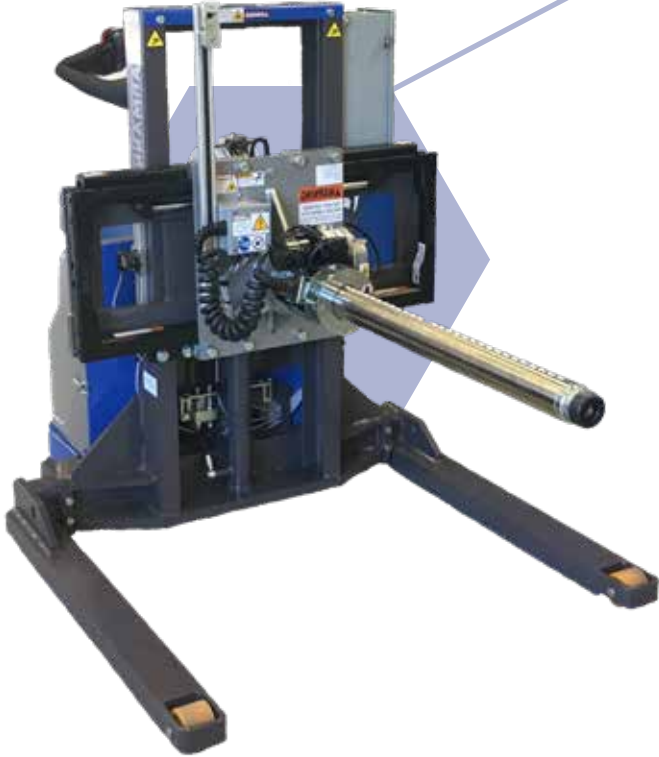

Powered horizontal roll handling lifts are used to lift, transport load and unload rolls and products. Tooling options, custom and standard, are designed by Schlumpf and offer users a variety of productivity enhancing benefits.

Custom Capacities Available!

Options:

- ◆ Straddle or Counter Balanced legs
- ◆ Hydraulic Side shift
- ◆ Camera System
- ◆ Roll Pusher
- ◆ Dual Stage Mast
- ◆ Laser System



**Quick Change Battery Cart*

Capacities dependent on roll specifications. Please contact us for more information.

V-CRADLE

Roll Mover



Our powered lift trucks with cradle tooling make moving large rolls around easy! With powered drive and lift mechanisms they can achieve a multitude of jobs.

- ◆ 2 Speed operation
- ◆ Custom Configurations Available
- ◆ Able to load unwind/rewind shafts
- ◆ Hydraulic lip to mate with pallet
- ◆ Contoured forks available
- ◆ Custom capacities available!

Options:

- ◆ Straddle or Counter Balanced legs
- ◆ Hydraulic Side shift
- ◆ Dual Stage Mast



Capacities dependent on roll specifications. Please contact us for more information.

CUSTOM

Powered Mobile Solutions

Our engineers can design a powered machine tooling to fit your exact specifications! Tailored designs ranging from OD clamping, to mobile roll up-enders. We can accommodate any of your industrial material handling needs.



Contact our sales team if you are interested in a custom design!



SCHLUMPF USA

Shaft Handling Solutions

Schlumpf's portable hydraulic and electric shaft handling machines are a versatile tool for many shaft handling applications. Designed for portability, ease of use, compact design, and flexibility. Eliminate any risk of operator injury and make lifting, inserting, extracting and transporting heavy shafts, safe and easy.

- ◆ Flexible Packaging

- ◆ Food Packaging

- ◆ Pharma Packaging



- ◆ Medical Packaging

- ◆ Converting and Printing

- ◆ Aerospace

ESH-400

Electric Shaft Handler



Our light-duty portable electric shaft handlers are a versatile tool for many shaft handling applications.

- ◆ Easy to push and maneuver
- ◆ Rugged
- ◆ Low Maintenance
- ◆ Powerful Electric Clamp
- ◆ Custom Column Heights

Custom Capacities! Tooling is designed for your specific shaft handling requirements!

Options:

- ◆ Adjustable Straddle or Euro Style legs
- ◆ Manual clamp options available
- ◆ Adjustable Limit Switches
- ◆ Laser Targeting
- ◆ Video Camera System
- ◆ Pivot Tooling



**Laser Targeting*



SCHLUMPF USA

POWERED SHAFT HANDLER

Powered Shaft Handler

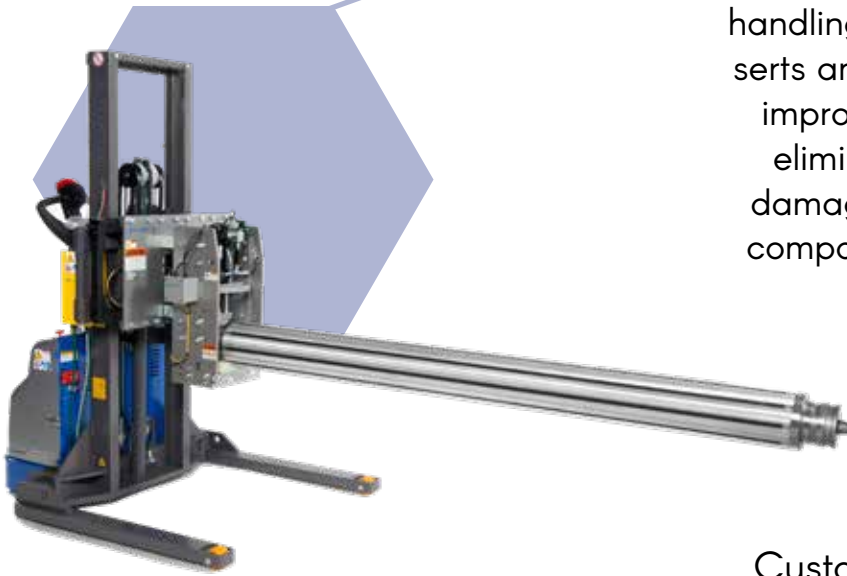

Our heavy duty shaft handler is the safest, most rugged, precise and user friendly shaft handling machine available today! Lifts, inserts and extracts heavy expanding shafts, improving productivity AND completely eliminating the risk of both equipment damage and operator injury, saving your company money and valuable resources.

Custom Capacities! Tooling is designed for your specific shaft handling requirements!

Options:

- ◆ Laser Targeting
- ◆ Video Camera Integration
- ◆ Hydraulic side shift option
- ◆ Hydraulic tooling tilt up option
- ◆ Accommodates multiple shaft diameters with easy to change anvils.
- ◆ Shaft presence sensor with lift override switch
- ◆ Travel speed restriction when load is raised
- ◆ Fixed straddle, adjustable or Euro style legs
- ◆ Clamp pressure sensor.
- ◆ Adjustable Cradle designs available



SCHLUMPF USA

Roll Carts

Schlumpf offers a wide range of portable roll carts. We are confident that we can meet your needs, regardless of your industry or application. Custom solutions are available for clients with highly-specialized needs.

◆ Flexible Packaging

◆ Food Packaging

◆ Pharma Packaging



◆ Medical Packaging

◆ Converting and Printing

◆ Aerospace

VCRD

Roll Dolly



The VCRD's rugged steel construction and powder coated finish is durable and handles the heaviest loads with ease.

Numerous options are available including quick-mount handlebars and self-stacking posts to keep the dolly out of the way when not in use. The VCRD is a perfect compliment to other Schlumpf roll and shaft handling systems. Custom designs are available!

Capacity of 1000lbs (454kg).



Capacities dependant on roll specifications. Please contact us for more information.



HRC portable hydraulic powered roll handling carts make lifting and transporting rolls and other heavy items with weights to 1100 lbs (500 kg) safe and easy. The HRC's powerful, compact design features a high-speed foot pedal operated hydraulic lift with ergonomic hand lever for lowering the table by gravity.

Capacities up to 1100 lbs (500kg).

- ◆ Foot pump lift mechanism.
- ◆ Ergonomic handlebar.
- ◆ Large casters. Easy to position and control.
- ◆ Modular design. Custom configurations available.
- ◆ Savings in manpower requirements.
- ◆ Increased workplace safety.
- ◆ PV90 or 360 Swivel Top available.
- ◆ Reduced operator fatigue.
- ◆ Lightweight, operator friendly design.
- ◆ Rugged steel construction.
- ◆ Multiple table configurations available.
- ◆ Electric Lift Available.

Capacities dependent on roll specifications. Please contact us for more information.

Schlumpf Custom

Our engineers can design more than just custom tooling. Fully custom machines are also an option if you have a highly specialized job!

- ◆ Flexible Packaging

- ◆ Food Packaging

- ◆ Pharma Packaging



- ◆ Medical Packaging

- ◆ Converting and Printing

- ◆ Aerospace

CUSTOM

Lift Tables



Our custom lift table designs can handle rolls, machine parts and much more!

These highly customizable, heavy duty tables can be tailored to your exact needs and specifications.

Contact our sales department today if you have an application you would like us to look at!

Our hands-on sales engineers can develop a plan to tackle even your most difficult handling job, safely and efficiently.



SCHLUMPF USA

CUSTOM

Lift Tables



Our custom lift table designs can handle rolls, machine parts and much more!

These highly customizable, heavy duty tables can be tailored to your exact needs and specifications.

Contact our sales department today if you have an application you would like us to look at!

Our hands-on sales engineers can develop a plan to tackle even your most difficult handling job, safely and efficiently.



SCHLUMPF USA

CUSTOM

Upenders



Our Hydraulic Roll Up-enders (HRUP) are custom built to fit your needs and roll specifications.

Contact our sales department today if you have an application you would like us to look at!

Our hands-on sales engineers can develop a plan to tackle even your most difficult handling job, safely and efficiently.



SCHLUMPF USA

CUSTOM

Armanni Pallet Lifters

Armanni pallet lifters are a great addition to any warehouse or job site to move around pallets full of materials or parts, safely, and easily.



Counter balanced units are also an option for getting to pallets that have little to no leg room



Four-way directional options are also available!



SCHLUMPF USA

Drum Handling Solutions

Drums are heavy and difficult to handle even when empty! The contents can be messy, corrosive and sometimes dangerous. Don't risk an accident or injury, and make drum handling as safe and efficient as possible. Lift, load, move, store, or meter with easy to use drum handlers from Armani.

◆ Flexible Packaging

◆ Food Packaging

◆ Pharma Packaging



◆ Medical Packaging

◆ Converting and Printing

◆ Aerospace

PARROT BEAK

Drum Handler



- ◆ Heavy Duty Construction
- ◆ Automatic parrot beak grips drums when lifted, and releases when lowered.
- ◆ Capacity of 660lbs (300kg)
- ◆ Optional Weighing Scale for metering
- ◆ Ergonomic, fast and easy movement of drums
- ◆ Single stage Powered mast lift

Contact us for information on custom designs or stainless steel options!



SCHLUMPF USA

OD CLAMP

Drum Handler



Manual

- Heavy Duty Construction
- Manual OD clamp or strap, with powered or manual drive options
- Optional Weighing Scale for metering
- Straddle Legs
- Single or dual stage mast lift

Powered

- Heavy Duty Construction
- OD clamp with hydraulic or electric, frontal or side turner.
- Optional Weighing Scale for metering
- Straddle Legs or Counter Balanced base
- Single or dual stage mast lift



SCHLUMPF USA

STRAP CLAMP

Drum Handler



Manual

- ◆ Simple design for occasional use.
- ◆ Manual OD strap, with manual frontal turner
- ◆ Heavy Duty Construction
- ◆ Straddle Legs
- ◆ Manual single stage mast lift

Powered

- ◆ Heavy Duty Construction
- ◆ OD Strap with hydraulic or electric manual, frontal turner.
- ◆ Optional Weighing Scale for metering
- ◆ Straddle Legs or Counter Balanced base
- ◆ Single or dual stage mast lift



SCHLUMPF USA

Outdoor Pallet Trucks and Industrial Tuggers

All-terrain pallet trucks are an excellent option for any outdoor or multi-environment job! These easy to maneuver trucks can tackle everything from gravel, grass, and slippery surfaces.

Industrial Tuggers are great for moving all kinds of heavy materials and equipment on smooth or rough terrain!

- ◆ Flexible Packaging

- ◆ Food Packaging

- ◆ Pharma Packaging



- ◆ Medical Packaging

- ◆ Converting and Printing

- ◆ Aerospace

CONHERSA EPT/H2

All Terrain Pallet Truck



The CONHERSA EPT and H2 rough terrain pallet trucks are designed for moving loads up to 3300lbs (1500kg) on uneven terrain.

- ◆ Designed for outdoor or indoor use
- ◆ Heavy duty steel construction
- ◆ Manual or Powered drive available
- ◆ Variable speed tiller switch
- ◆ Ergonomic easy-steer tiller
- ◆ Battery charge indicator
- ◆ 7.87in (200mm) lift height
- ◆ Adjustable Fork Carriage



SCHLUMPF USA

CONHERSA ET1000

All Terrain Pallet Truck



ET-1000 lifts are great in any terrain! Dirt, mud, gravel or ice and snow will not stop this machine from lifting and moving material of all shapes and sizes.

Capacities up to 2200lbs
(1000kg)

- ◆ Designed for outdoor or indoor use
- ◆ Heavy duty steel construction
- ◆ Powered drive
- ◆ Variable speed tiller switch
- ◆ Ride on platforms available
- ◆ Ergonomic easy-steer tiller
- ◆ Battery charge indicator
- ◆ Optional lift heights
- ◆ Adjustable Class II fork carriage

TUGGERS

Armanni Tugger

Armanni tuggers and tows handle heavy loads safely and efficiently. Choose between tow hook or flat bed attachments to best fit your specific needs!



***Contact our sales team for a wide range of
tugger options!***



SCHLUMPF USA



SCHLUMPF USA

www.schlumpf-inc.com
info@schlumpf-inc.com
207.893.1903